

# AIR-OPERATED INDUSTRIAL DISJOINT PUMPS FOR OIL AND CHEMICAL PRODUCTS Mod.902D HIGH DELIVERY

COMPRESSION RATIO = 2:1 DELIVERY CAPACITY = 95 l/min



## Art. 021-0902-DP0

Air-operated industrial disjoint pump for oil, lubricants and similar fluids  
Mod. 0902D HIGH DELIVERY

Ratio=2:1 double-acting Delivery capacity 95 l/min

For wall-fixing or fixed positions.

Polyurethane seals

## Art. 021-0902-DV0

Air-operated industrial disjoint pump for chemical fluids  
Mod. 0902D HIGH DELIVERY

Ratio=2:1 double-acting Delivery capacity 95 l/min

For wall-fixing or fixed positions.

Viton seals

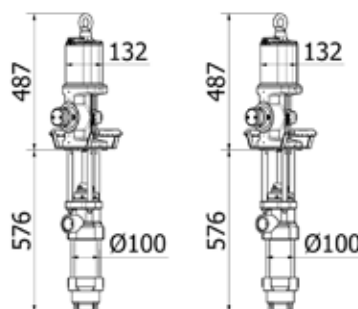

021-0902-DP0	38,200	0,110	1
021-0902-DV0	38,200	0,110	1

Technical Data		021-0902-DP0	021-0902-DV0
Compression ratio		2:1	2:1
Working pressure	bar	8	8
Air consumption at 8 bar	m³/min	1,75	1,75
Air inlet connection	BSP	F 1/2" G	F 1/2" G
Fluid outlet connection	BSP	F 1.1/2" G	F 1.1/2" G
Fluid delivery cap. at 8 bar	l/min	95	95
Noise	dB	80	80
Shank diameter	mm	100	100
Shank length	mm	Modular F 2"	Modular F 2"

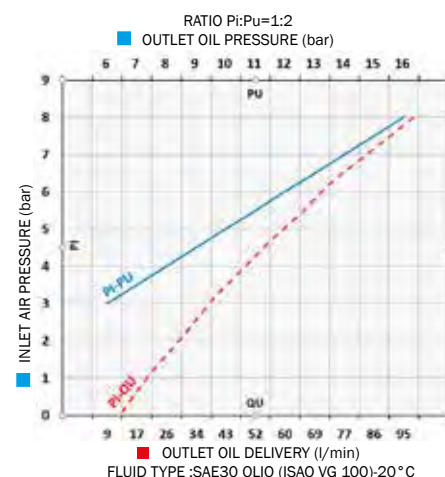

Automatic engine body and shank kit are divided in order to avoid that the fluid enters directly in contact with motor body. These pumps are advised for the transfer of oil and industrial fluids for medium-long distances, guarantee high performance as per delivery capacity (l/min) and also for working pressure.

The delivery capacity of a pump varies according to particular applications and combinations.

The operating pressure may vary between a minimum of 3 bar and a maximum of 8 bar. The double-acting guarantees the delivery of a continuous and constant flow, suitable for installations on distribution facilities. To optimize the performance and the time-life of the air-operated pumps we advise to use filtered and lubricated air.